

MOMENT OF A COUPLE

Today's Objectives:

Students will be able to

- define a couple, and,
- determine the moment of a couple.

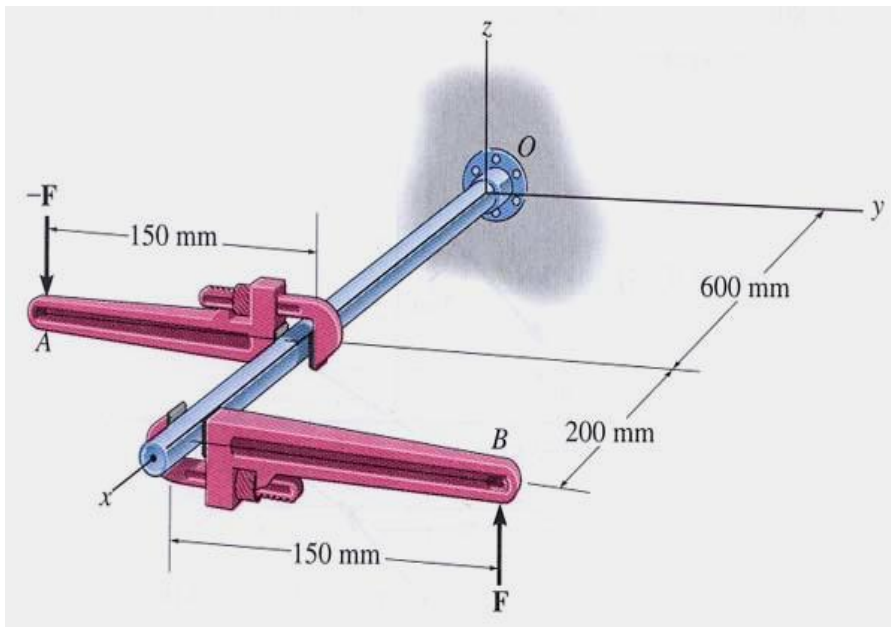

APPLICATIONS

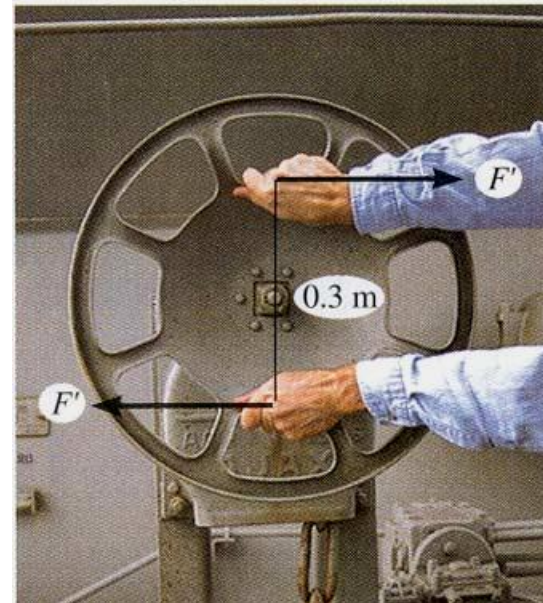
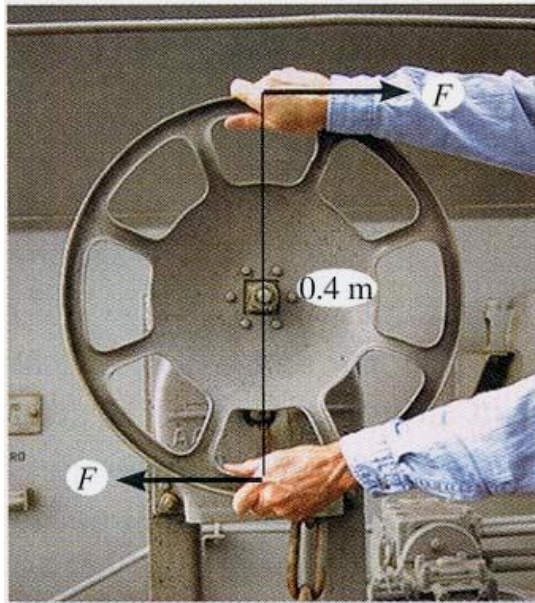

A torque or moment of $12 \text{ N} \cdot \text{m}$ is required to rotate the wheel. Which one of the two grips of the wheel above will require less force to rotate the wheel?

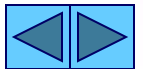

APPLICATIONS

(continued)

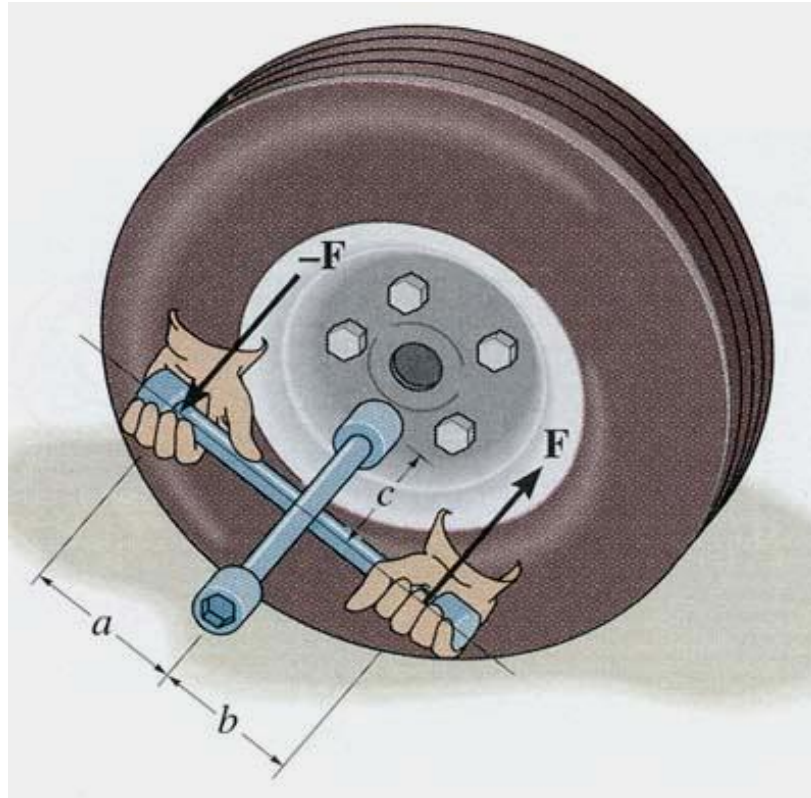

The crossbar lug wrench is being used to loosen a lug nut. What is the effect of changing dimensions a , b , or c on the force that must be applied?

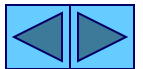

MOMENT OF A COUPLE

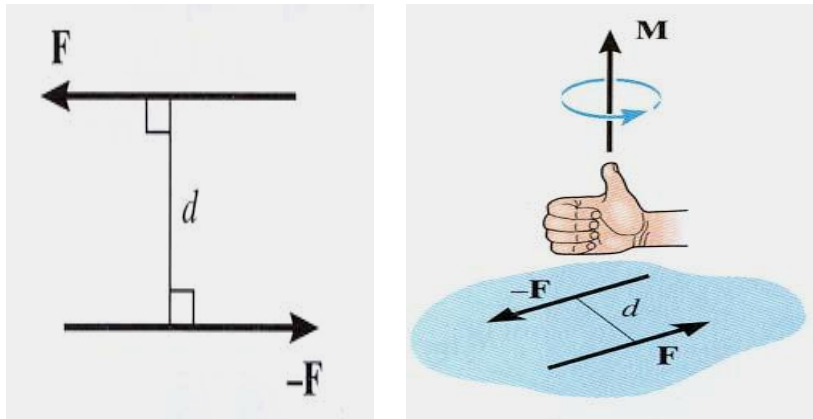

A couple is defined as two parallel forces with the same magnitude but opposite in direction separated by a perpendicular distance d .

The moment of a couple is defined as

$M_O = F d$ (using a scalar analysis) or as

$M_O = \mathbf{r} \times \mathbf{F}$ (using a vector analysis).

Here \mathbf{r} is any position vector from the line of action of $-\mathbf{F}$ to the line of action of \mathbf{F} .

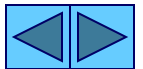

Couple moment only depends on F and d

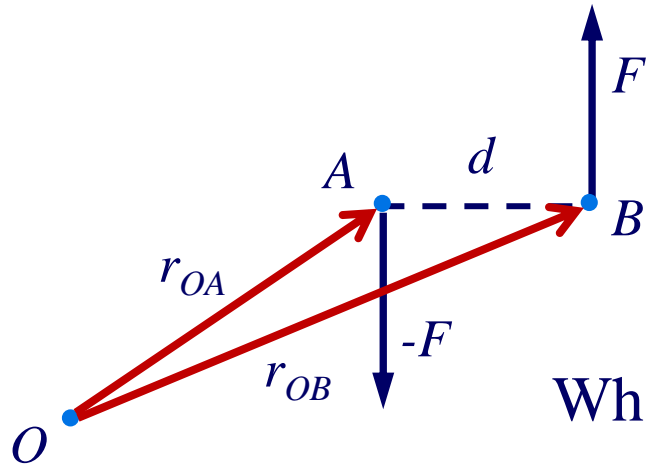

→

$$M_A = + dF$$

→

$$M_B = + dF$$

What about point O , is $M_O = + dF$ too?

First note

→

$$= \quad (\quad)$$

=

=

MOMENT OF A COUPLE

(continued)

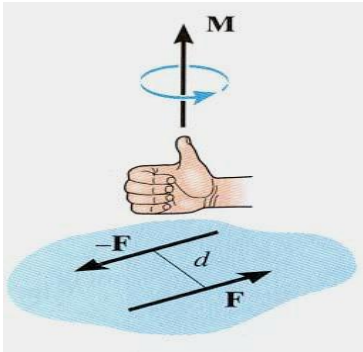

The net external effect of a couple is that the net force equals zero and the magnitude of the net moment equals $F d$

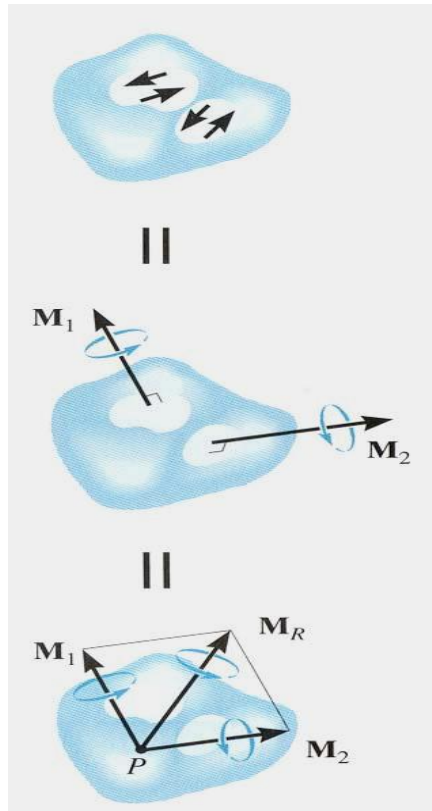

Since the moment of a couple depends only on the distance between the forces, the moment of a couple is a free vector. It can be moved anywhere on the body and have the same external effect on the body.

Moments due to couples can be added using the same rules as adding any vectors.

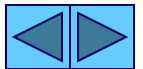

EXAMPLE - SCALAR APPROACH

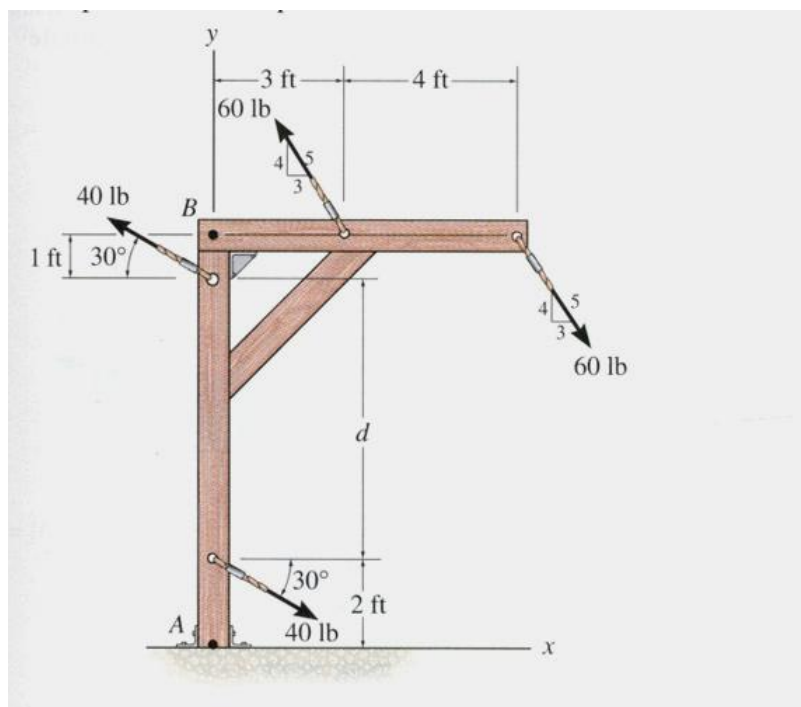

Given: Two couples act on the beam and d equals 8 ft.

Find: The resultant couple

Plan:

- 1) Resolve the forces in x and y directions so they can be treated as couples.
- 2) Determine the net moment due to the two couples.

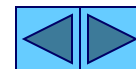

EXAMPLE - SCALAR APPROACH

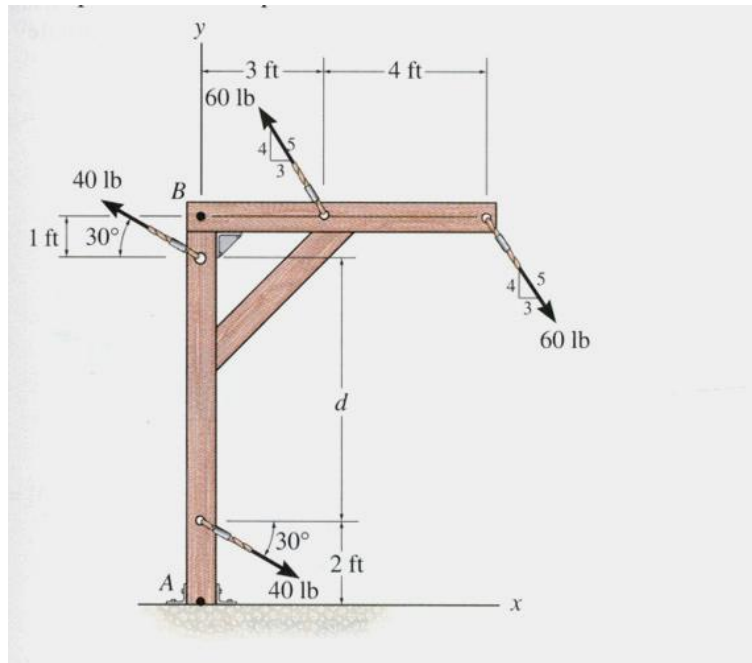

The x and y components of the top 60 lb force are:

$$(4/5)(60 \text{ lb}) = 48 \text{ lb vertically up}$$

$$(3/5)(60 \text{ lb}) = 36 \text{ lb to the left}$$

Similarly for the top 40 lb force:

$$(40 \text{ lb}) (\sin 30^\circ) \text{ up}$$

$$(40 \text{ lb}) (\cos 30^\circ) \text{ to the left}$$

The net moment equals to

$$+ \left(\sum M = -(48 \text{ lb})(4 \text{ ft}) + (40 \text{ lb})(\cos 30^\circ)(8 \text{ ft}) \right)$$

$$= -192.0 + 277.1 = 85.1 \text{ ft}\cdot\text{lb}$$

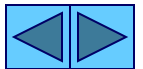

VECTOR APPROACH

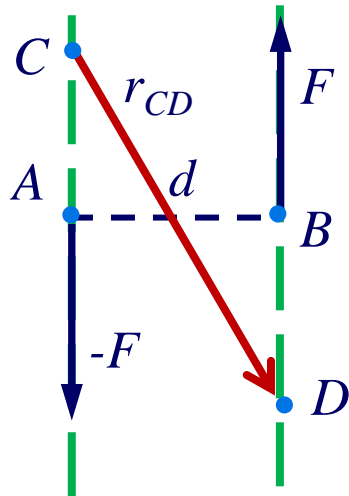

d is not always easy to see in 3D.

Can use any point on one line of action to the other as long as you have the coordinates of the points.

→ →

→ →

EXAMPLE – VECTOR APPROACH

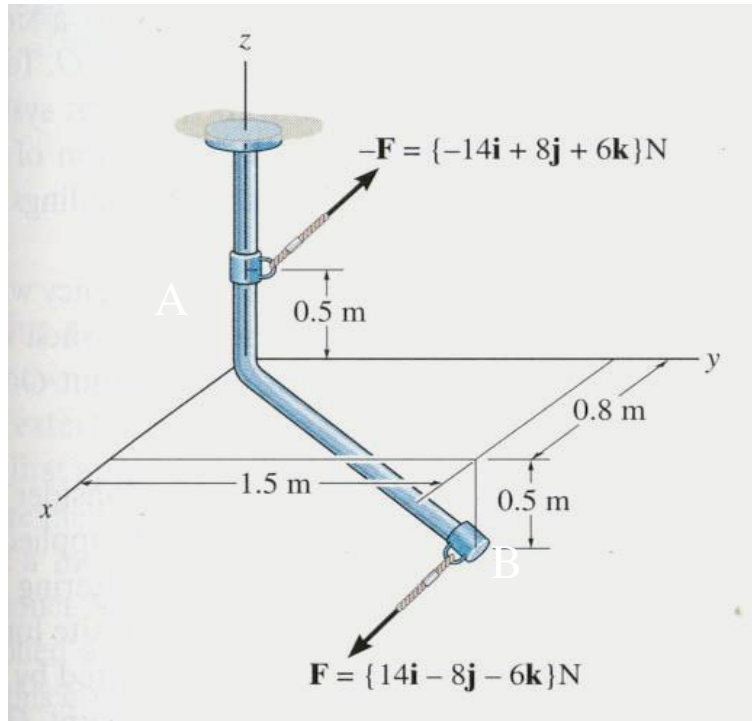

Given: A force couple acting on the rod.

Find: The couple moment acting on the rod in Cartesian vector notation.

Plan:

- 1) Use $\mathbf{M} = \mathbf{r} \times \mathbf{F}$ to find the couple moment.
- 2) Set $\mathbf{r} = \mathbf{r}_{AB}$ and $\mathbf{F} = \{14\mathbf{i} - 8\mathbf{j} - 6\mathbf{k}\}$ N.
- 3) Calculate the cross product to find \mathbf{M} .

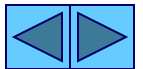

EXAMPLE – VECTOR APPROACH

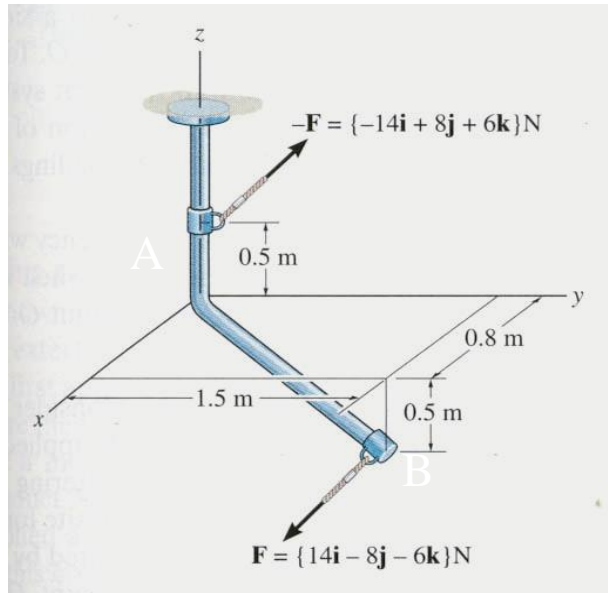

$$\mathbf{r}_{AB} = \{0.8 \mathbf{i} + 1.5 \mathbf{j} - 1 \mathbf{k}\} \text{ m}$$

$$\mathbf{F} = \{14 \mathbf{i} - 8 \mathbf{j} - 6 \mathbf{k}\} \text{ N}$$

$$\mathbf{M} = \mathbf{r}_{AB} \times \mathbf{F}$$

$$= \begin{vmatrix} \mathbf{i} & \mathbf{j} & \mathbf{k} \\ 0.8 & 1.5 & -1 \\ 14 & -8 & -6 \end{vmatrix} \text{ N}\cdot\text{m}$$

$$= \{\mathbf{i} (-9 - (8)) - \mathbf{j} (-4.8 - (-14)) + \mathbf{k} (-6.4 - 21)\} \text{ N}\cdot\text{m}$$

$$= \{-17 \mathbf{i} - 9.2 \mathbf{j} - 27.4 \mathbf{k}\} \text{ N}\cdot\text{m}$$

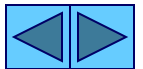

CONCEPT QUIZ

1. F_1 and F_2 form a couple. The moment of the couple is given by _____ .

A) $r_1 \times F_1$

B) $r_2 \times F_1$

C) $F_2 \times r_1$

D) $r_2 \times F_2$

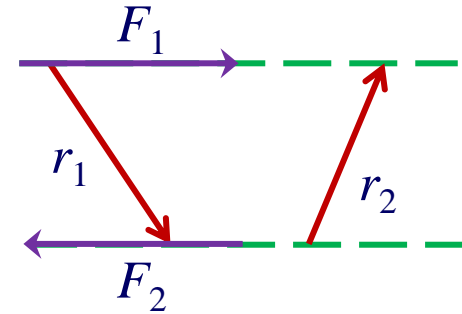

2. If three couples act on a body, the overall result is that

A) the net force is not equal to 0.

B) the net force and net moment are equal to 0.

C) the net moment equals 0 but the net force is not necessarily equal to 0.

D) the net force equals 0 but the net moment is not necessarily equal to 0 .

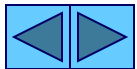

GROUP PROBLEM SOLVING – SCALAR APPROACH

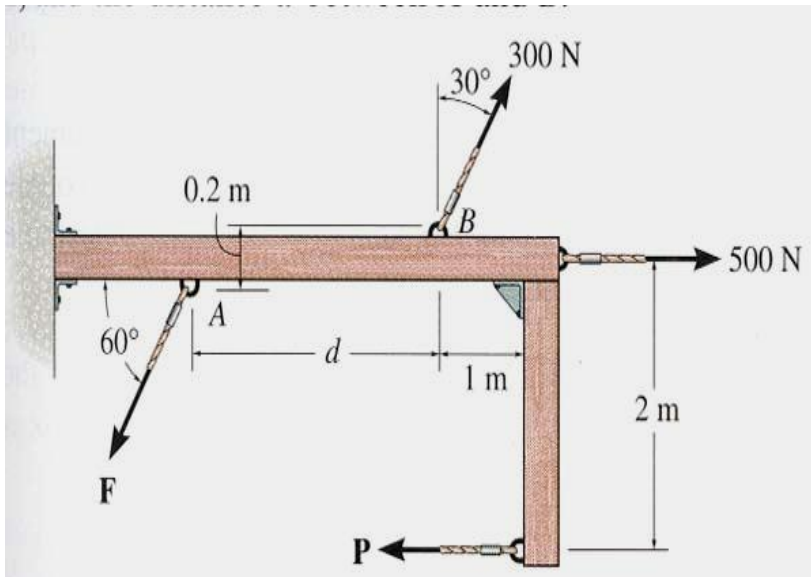

Given: Two couples act on the beam. The resultant couple is zero.

Find: The magnitudes of the forces P and F and the distance d .

PLAN:

- 1) Use definition of a couple to find P and F .
- 2) Resolve the 300 N force in x and y directions.
- 3) Determine the net moment.
- 4) Equate the net moment to zero to find d .



GROUP PROBLEM SOLVING – SCALAR APPROACH

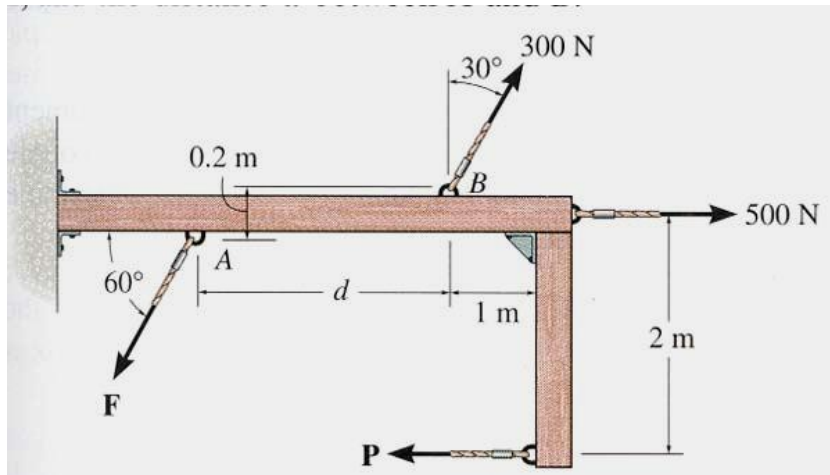

From the definition of a couple:

$$P = 500 \text{ N and}$$

$$F = 300 \text{ N.}$$

Resolve the 300 N force into vertical and horizontal components. The vertical component is $(300 \cos 30^\circ)$ N and the horizontal component is $(300 \sin 30^\circ)$ N.

It was given that the net moment equals zero. So

$$+ \left(\sum M = - (500)(2) + (300 \cos 30^\circ)(d) - (300 \sin 30^\circ)(0.2) = 0 \right.$$

Now solve this equation for d .

$$d = (1000 + 60 \sin 30^\circ) / (300 \cos 30^\circ) = 3.96 \text{ m}$$

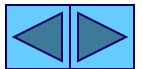

GROUP PROBLEM SOLVING – VECTOR APPROACH

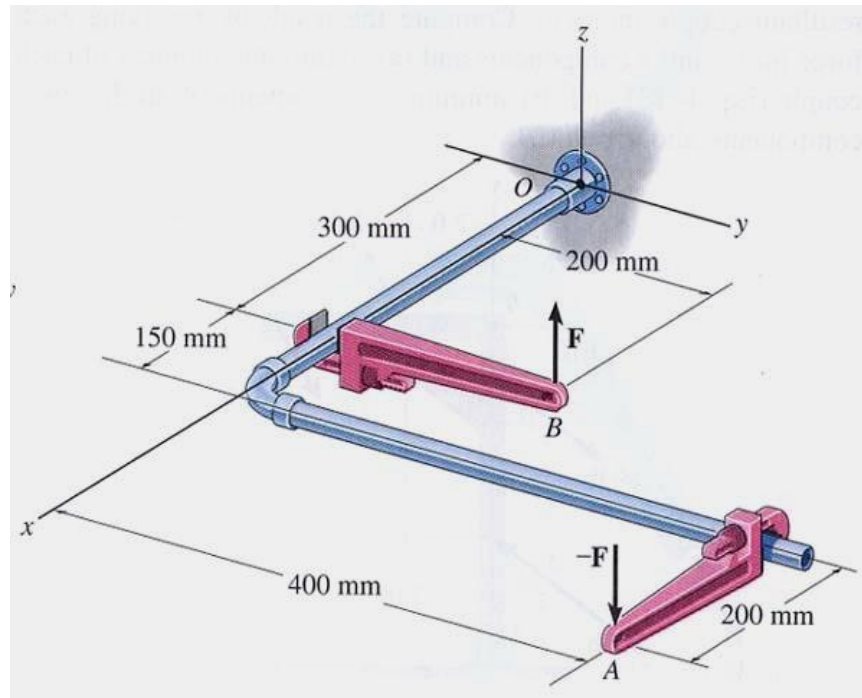

Given: $F = \{25 \mathbf{k}\}$ N and
 $-F = \{-25 \mathbf{k}\}$ N

Find: The couple moment acting on the pipe assembly using Cartesian vector notation.

PLAN:

- 1) Use $M = \mathbf{r} \times \mathbf{F}$ to find the couple moment.
- 2) Set $\mathbf{r} = \mathbf{r}_{AB}$ and $\mathbf{F} = \{25 \mathbf{k}\}$ N.
- 3) Calculate the cross product to find M .

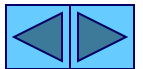

GROUP PROBLEM SOLVING – VECTOR APPROACH

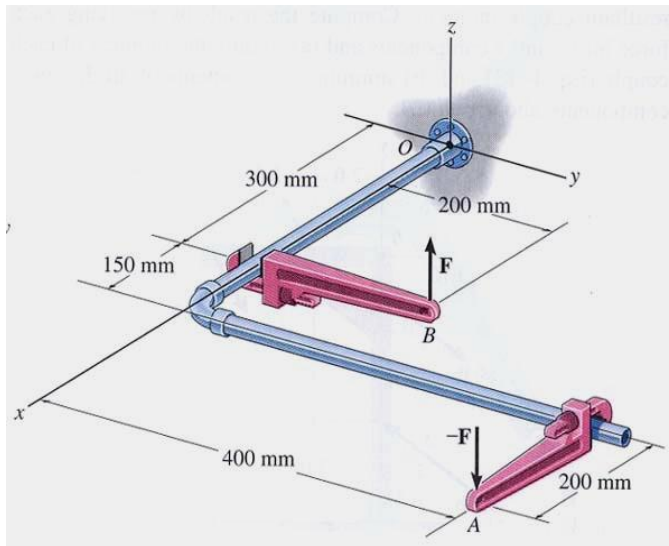

$$\mathbf{r}_{AB} = \{ -350 \mathbf{i} - 200 \mathbf{j} \} \text{ mm}$$

$$= \{ -0.35 \mathbf{i} - 0.2 \mathbf{j} \} \text{ m}$$

$$\mathbf{F} = \{ 25 \mathbf{k} \} \text{ N}$$

$$\mathbf{M} = \mathbf{r}_{AB} \times \mathbf{F}$$

$$= \begin{vmatrix} \mathbf{i} & \mathbf{j} & \mathbf{k} \\ -0.35 & -0.20 & 0 \\ 0 & 0 & 25 \end{vmatrix} \text{ N}\cdot\text{m}$$

$$= \{ \mathbf{i} (-5 - 0) - \mathbf{j} (-8.75 - 0) + \mathbf{k} (0) \} \text{ N}\cdot\text{m}$$

$$= \{ -5 \mathbf{i} + 8.75 \mathbf{j} \} \text{ N}\cdot\text{m}$$

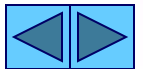

ATTENTION QUIZ

1. A couple is applied to the beam as shown. Its moment equals _____ N·m.

A) 50

B) 60

C) 80

D) 100

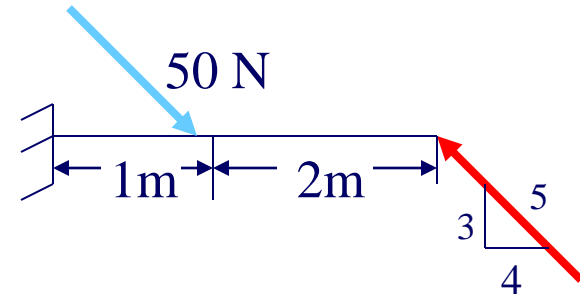

2. You can determine the couple moment as $\mathbf{M} = \mathbf{r} \times \mathbf{F}$

If $\mathbf{F} = \{ -20 \mathbf{k} \}$ lb, then \mathbf{r} is

A) \mathbf{r}_{BC}

B) \mathbf{r}_{AB}

C) \mathbf{r}_{CB}

D) \mathbf{r}_{AC}

